

ORSEZ®

INDUSTRIAL DOORS

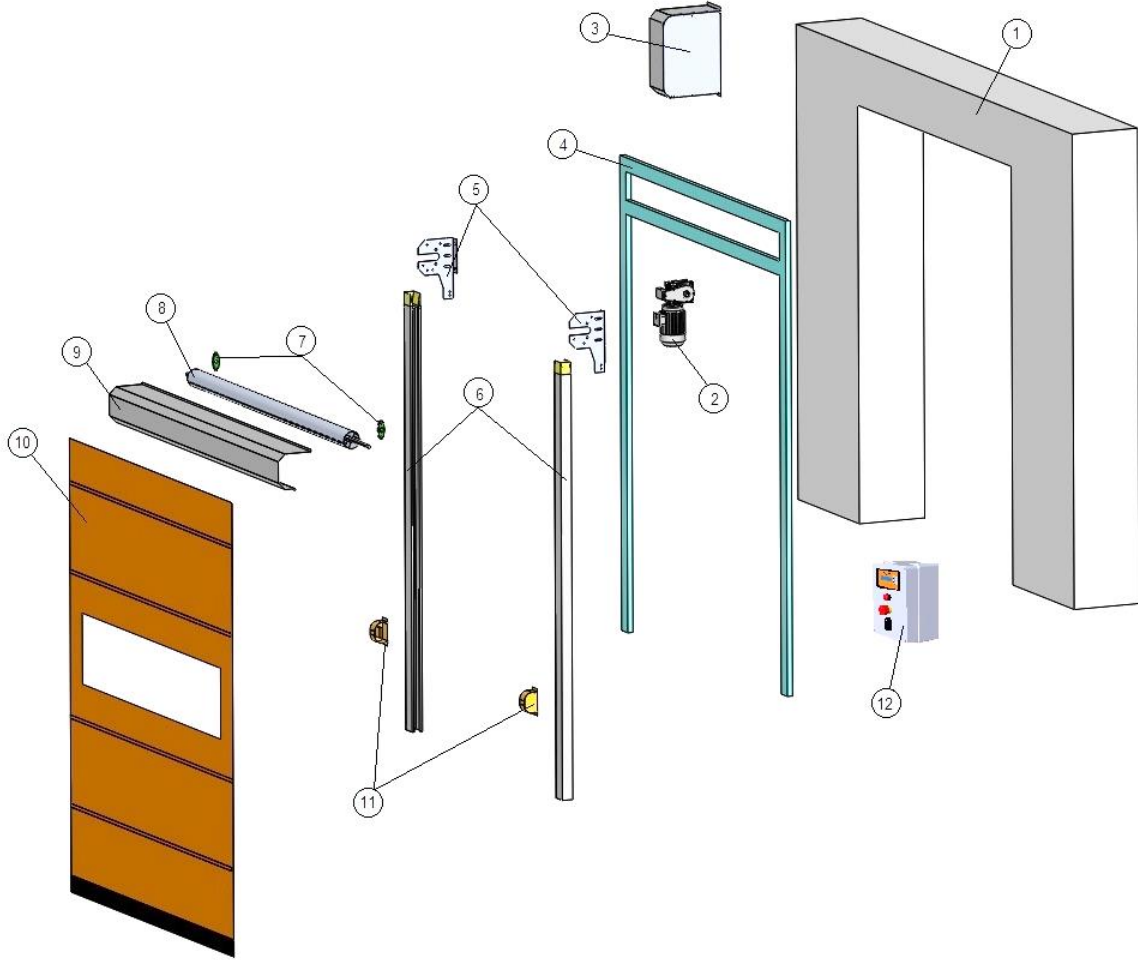

MODEL 100 / 101 / 102 MOUNTING INSTRUCTIONS



1. MOUNTING FLOOR OR BASE

2. ENGINE

3. ENGINE COVER

4. RAW DOOR CASE

5. VERTICAL STRUCTURE FLAG

6. GUIDING SEWING

7. BEARING

8. DRUM

9. TOP COVER

10. TAPE (TARPAULIN)

11. PHOTOCCELL

12. BOARD

VERTICAL GUIDANCE STRUT AND TARPAULIN INSTALLATIONS

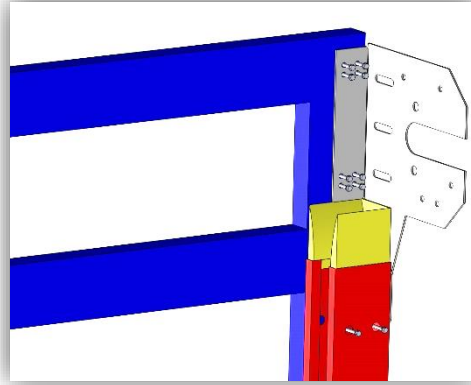

Struts and stanchion flags are mounted from screw holes to the blind door case by using self-tapping screws.

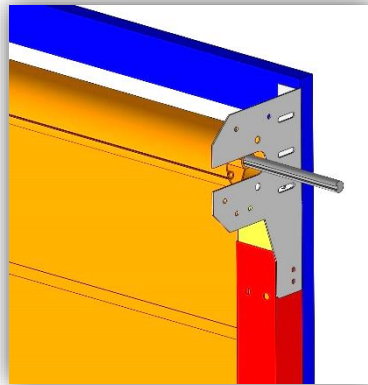

The tarpaulin part is passed to the flag channel on the strut together with the drum.

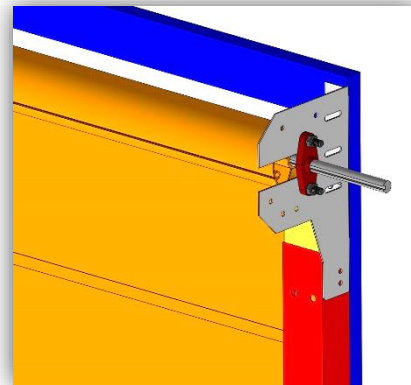
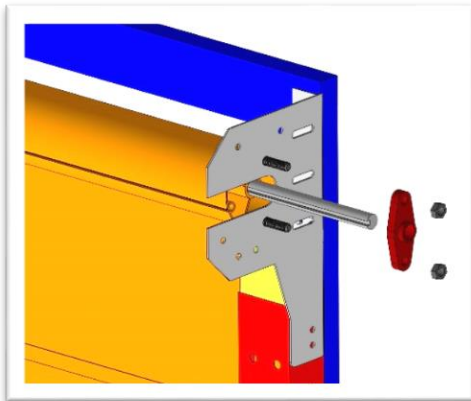

The bearings are passed to the drum shaft and connected to the flag with bolts and nuts.

ENGINE INSTALLATION

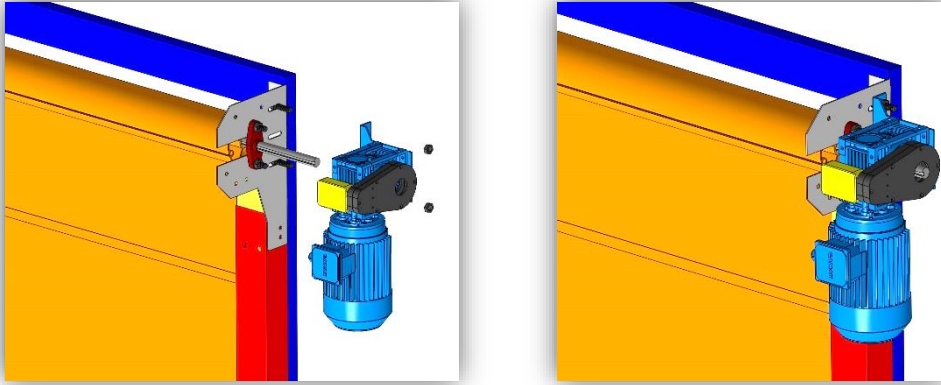

It is tightened with bolts so that it coincides with the flag holes on the strut with the engine plate.

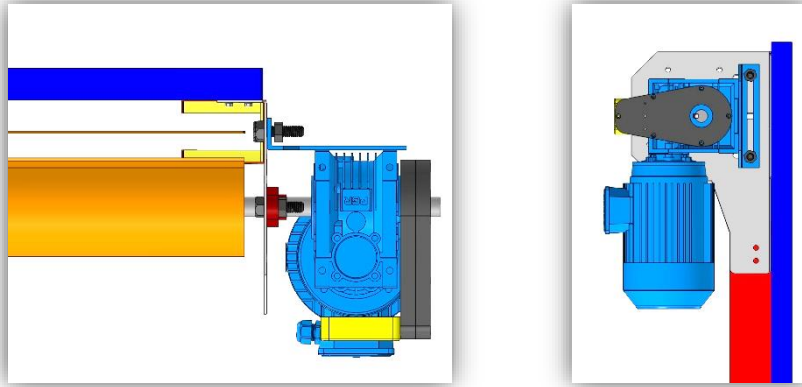

After assembly view from top and side

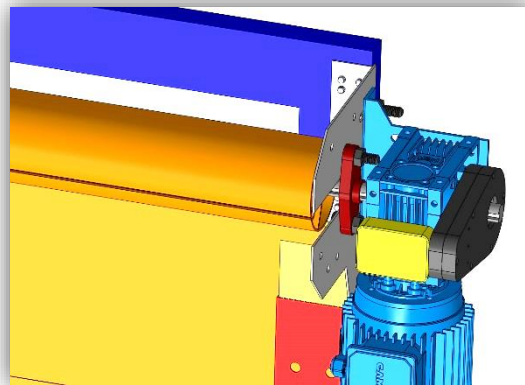

Detailed view

TOP COVER AND ENGINE COVER INSTALLATION

MODEL 100 / 101 / 102 MONTAJ KLAVUZU

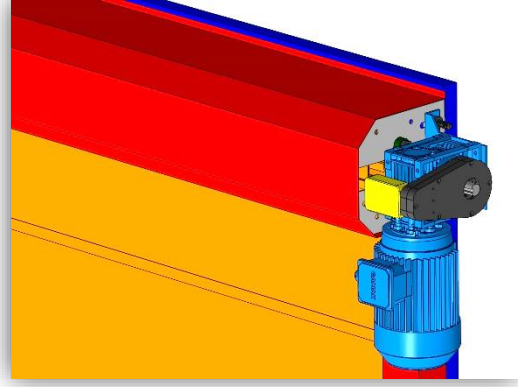
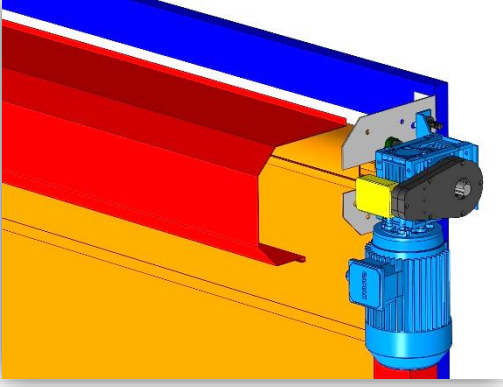

The top cover corners are fixed in place so that the top of the post coincides with the flag corners.

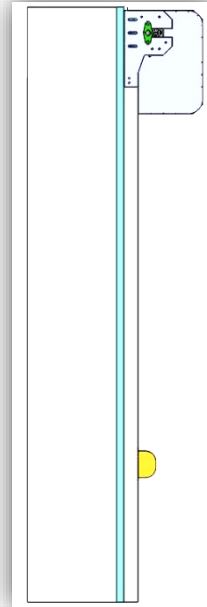
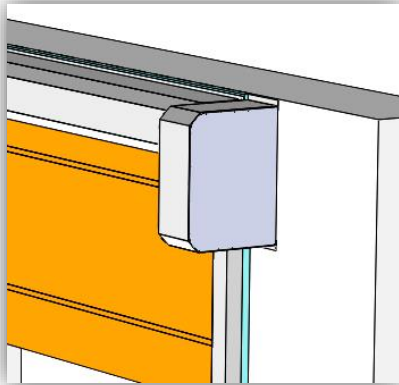

The motor cover is placed inside the motor and mounted on the wall in line with the upper cover.

View of finished mounting

